

Solatube® SolaMaster® Series Installation Instructions 21" Solatube (530mm)

Please read all warnings and instructions before beginning the installation.

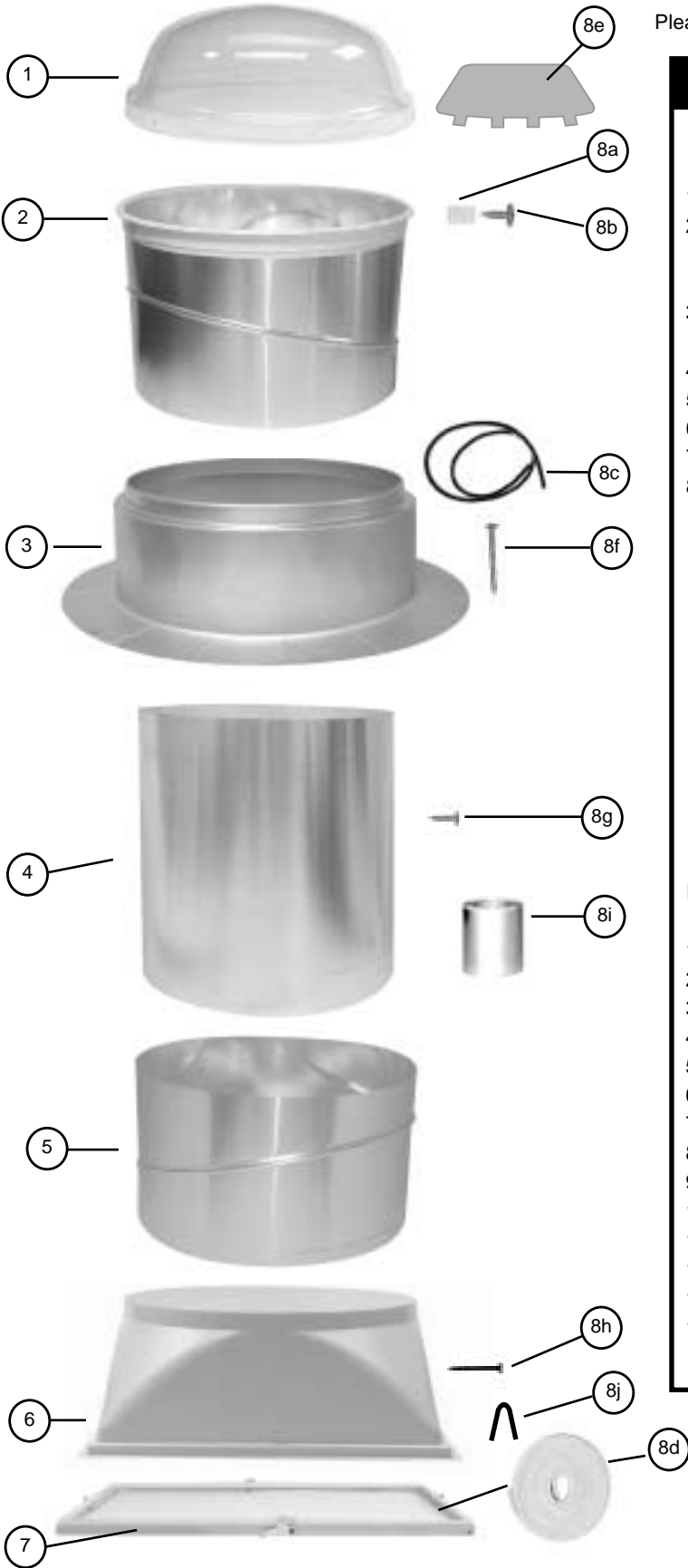

PARTS LIST

	Quantity
1. Duradome ¹⁰	(1)
2. Top Tube Assembly including	(1)
a. Dome Ring	
b. Spectralight® Delta Top Tube with Angle Adapter	
3. Roof Flashing (4" (102mm) , 8" (203mm), 11" (279mm) or Curb Mount)	(1)
4. Spectralight® Infinity 24" (610mm) Extension Tube	(optional)
5. Spectralight® Delta Bottom Tube with Angle Adapter	(1)
6. Transition Box	(1)
7. Diffuser	(1)
8. Seal and Fastener kit including	
a. Dome Spacers	(6)
b. Dome Screws - #8 X 3/4" (19mm)	(6)
c. Dome Seal	(1)
d. Diffuser Seal	(1)
e. LITD®, (Light Intercepting Transfer Device)	(1)
f. Flashing Screws - #10 X 2" (51mm)	(20)
g. Tube Screws - #8 X 3/8" (10mm)	(16)
h. Drywall Mounting Screw - #8 X 1 1/2" (38mm)	(4)
i. 2" (51mm) Foil Tape – 18' (5.5m) roll	(3)
j. Transition hold down clip	(4)

Required Tools:

1. Roof Sealant – 3 tubes (10.5 fl. oz./305ml)
2. Electric drill
3. Saber or Reciprocating Saw
4. #2 Phillips Head Screw Driver / Screw Gun
5. Utility Knife or Razor Knife
6. Tape Measure
7. Flat Bar
8. Metal Shears
9. Flashlight
10. Caulking Gun
11. Ladder
12. Plumb Bob
13. Magnetic Compass
14. Required Safety Equipment



WARNING



Do not proceed with the installation until you have read the entire instructions, including these warnings.

Solatube (seller) assumes no responsibility or obligation whatsoever for the failure of an architect, contractor, installer, or building owner to comply with all applicable laws, ordinances, building codes, energy codes, fire and safety codes and requirements, roof warranties and adequate safety precautions. Installation of this product should be attempted only by individuals skilled in the use of the tools and equipment necessary for installation. Protect yourself and all persons and property during installation. If you have any doubt concerning your competence or expertise, consult a qualified expert before proceeding.

Install at your own risk!

Solatube product installations may be dangerous and include the potential for death, personal injury and property damage. The hazardous conditions include but are not limited to the following:

- During installation, the Solatube's reflective tubes may focus sunlight, causing intense heat or fire. Remove protective film only after the parts have been installed. Prior to and during installation, do not leave tubes in contact with combustible materials or unattended, especially near direct sunlight. Avoid skin burns.
- Sheet metal edges may be sharp. Use protective gloves to avoid lacerations.
- Skylight installations require climbing and working at dangerous heights, including on ladders, scaffolding, roofs and in attic spaces. Risk of death, personal injury and property damage may result from a fall, or from falling objects. Use extreme caution to minimize risk of accidental injury, including, but not limited to the following procedures:
 - Clear area below your work space of all people, animals and other items.
 - Avoid working on surfaces that are slippery or wet.
 - Use foot-wear with excellent traction.
 - Use only strong, well supported ladders.
 - Work only in calm dry weather.
 - When in the attic, ensure that your weight is supported at all times with structurally sound framing; dry wall material is not designed to carry a person's weight.
- To reduce the risk of fire, electric shock, and personal injury; basic safety precautions should always be followed when using electric tools, including always wearing safety goggles or other suitable eye protection, and ensuring work area is clear of all electrical wires, gas pipes, water pipes, and other obstacles.
- When working in the attic or other dusty areas, use of a mask or respirator is recommended to avoid lung irritation. Attic spaces may be dark, confined, and subject to extreme temperatures. Beware of sharp protruding objects. Do not attempt installation without having someone within range of your voice or close enough to come to your aid if necessary.
- The tubular skylight is not designed to withstand the weight of a person, tools or other objects. Walking or placing objects on the skylight could cause personal injury and property damage. If the dome of the skylight is broken or cracked, or if the skylight is otherwise damaged, the structural capacity may be weakened, and the skylight should be repaired immediately. For safe installation and use, do not deviate from these installation instructions.

Installation Tips

These instructions are a step by step guide for the installation of a Solatube in the following conditions. For other roof types, please ask your Solatube dealer for additional information.

• Built Up Flat Roof

• Asphalt Shingle

• Low/No Pitched

• Pitched

- Allow at least 3 hours for the installation, particularly if this is your first installation.
- All adhesives, seals and tapes must be applied to a dry surface at a minimum of 70°F to be effective.
- During the day, turn off all the lights in the room to see how much natural light comes in through the windows, and determine the best position for the Solatube. To light a specific area, place the Solatube over the area, not in the center of the room. This will prevent the desired area from being shaded by tall objects in the room.
- Avoid roof locations shaded by trees, ridges and chimneys, or near water channels or valleys.
- Avoid attic areas with obstructions such as gas, water or drain pipes, air ducts, flues or furnaces.
- Measure the distance between the roof and the ceiling. If you don't have enough tubing to cover the distance, contact your Solatube dealer for additional tubes. Top tube and bottom tubes are 15.5" (394mm) long. Optional extension tubes are available: 24" (610mm) in length. All joints should overlap 1 1/2" (38mm) minimum. Order the combination which most economically achieves the length that you need.
- Make sure the roof is adequate to endure a Solatube installation without damaging its waterproofing properties.

MARKING THE CEILING LOCATION

Note: Requires 21 3/4" (553mm) of clearance between structural members.
 Step 1: Determine skylight location for optimum light performance. Make sure there are no obstructions in tube's path to roof or obstructions on roof restricting flashing or path of direct sunlight.

Suspended Ceiling

Step 2: Remove ceiling panel at chosen location. Transition box will replace a 2' x 2' (600mm x 600mm) ceiling panel. When installing into 2' x 4' (600mm x 1200mm) ceiling panel system, insert a 2' (600mm) cross T-bar.

Hard Ceiling

Step 2: Cut 22 7/8" x 22 7/8" (581mm x 581mm) square opening through ceiling material. Add 2" x 4" blocking to open ends. Shim 2" x 4" sides of opening to measure 21 3/4" x 21 3/4" (553mm x 553mm) (Diagram A). Fasten shims even at bottom of 2" x 4".

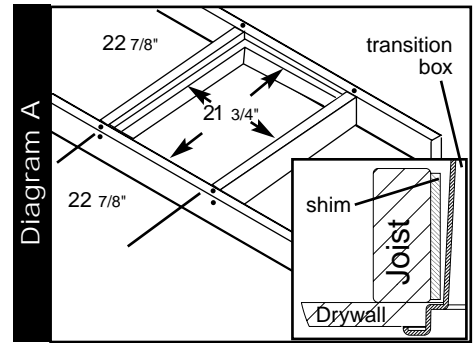

ROOF LOCATION

Note: If total tube length is 6' (1.8m) or greater, roof location may be moved towards the south, generating a 15° slope on tube maximizing tube performance.
 Exception: With north pitched roof, tube should only be installed vertically (Diagram B).

Suspended T-Bar Ceiling and Hard Ceiling

Step 3: Plumb a line from underside of roof down to center of ceiling location. Adjust the roof flashing location if necessary to avoid obstacles and ensure proper clearance. Mark location. Transfer location to rooftop surface with a screw or drill bit.

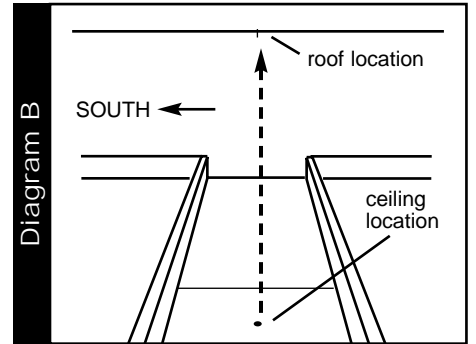

TRANSITION BOX INSTALLATION

Suspended Ceiling

Step 4: Place transition box into suspended ceiling grid in place of removed ceiling panel. Fasten transition box to T-bar ceiling grid using four V-shaped transition hold down clips. Install clip above suspended ceiling, 2" (51mm) in from each corner of the transition with "V" point of clip pressing downward against wall of transition and with legs leaning against vertical wall of T-bar. Push the legs of the clip downward until legs wedge under shoulder at top of T-bar (Diagram C).

Step 5: Remove protective liner from inside of bottom tube and set tube over round section of transition box (Diagram D). Sight up through the bottom tube towards roof flashing location. If installation is not vertical, adjust bottom tube angle to align with roof flashing location (Diagram E).

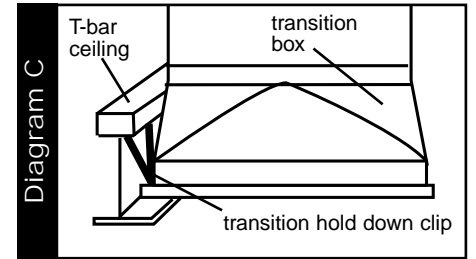

Hard Ceiling

Step 4: Remove protective liner from inside of bottom tube and slide tube over the round section of transition box (Diagram D). Insert transition box assembly into shimmed ceiling opening from the bottom.

Step 5: Sight through bottom tube towards roof location. If the installation is not vertical adjust bottom tube angle to align with roof flashing (Diagram E). Anchor in place using four 1 1/2" (38mm) drywall screws. Drive one screw through each side of transition box, 1 1/2" (38mm) up from the bottom.

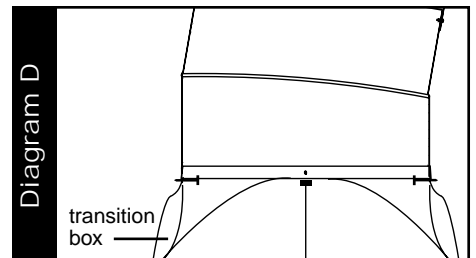

ROOF FLASHING INSTALLATION

Take flashing, flashing screws, top tube assembly, dome, dome screws, dome, screw spacers, LITD, foil tape, sealant, appropriate tools and safety equipment to roof flashing location.

Step 6: Remove backing from dome seal and firmly adhere it along the top rolled edge of flashing. Cut seal where ends meet making tight fit (Diagram F).

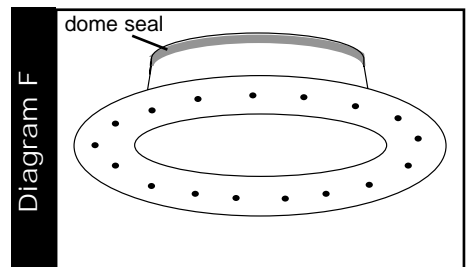
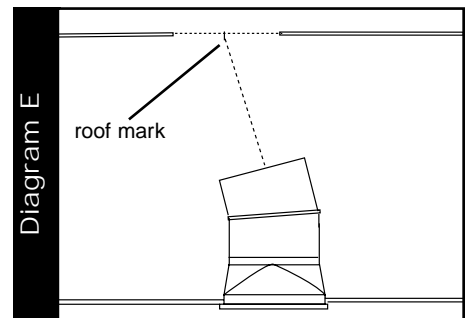

Flat/Low Pitch Roof

For built-up, cap sheet or roll roof systems follow instructions below. For foam, PVC, or torchdown roofs, consult a commercial roofing contractor for alternate flashing applications.

Step 7: Scrape and sweep away loose gravel and dirt from roof area where flashing will be located. Roof surface under flashing and 3" (76mm) beyond edge of flashing must be smooth and free of debris.

Step 8: Turn flashing upside down and center it over roof mark, then trace inside circumference onto roof surface with a lumber crayon (Diagram G). Cut hole through roof deck 1/2" (12.5 mm) outside marked line, being careful not to cut any framing members concealed pipes or electrical wires (Diagram H). Clean sawdust from around roof hole.

Step 9: Turn flashing upright. Center flashing on roof hole and trace outer edge of flashing. Apply a 3/4" (19mm) bead of sealant to roof 1" (25mm) inside perimeter of marked line, a 3/4" (19mm) bead of sealant on underside of flashing 1" (25mm) in from outside edge, and between layers of roofing exposed by flashing hole (Diagram I). Replace flashing to marked location and check for a proper seal. Fasten flashing to roof with 2" (51mm) flashing screws. Tighten screws until sealant is a minimum of 1/8" (3mm) and a maximum of 1/4" (6mm) thick between flashing and roofing material. Do not over tighten. Coat screw heads with sealant. Apply another bead of sealant to outer edge of flashing, spreading it evenly to seal flashing edge and roof surface.

Pitched Roof

Step 7: With flashing up right, center over roof mark and trace inside circumference onto roof with a lumber crayon. Using a utility knife or razor knife, cut shingles 1/2" (12.5 mm) outside marked line to expose roof deck. Turn flashing upside-down, center over roof location, and mark line on inside edge (Diagram G). Use saber or reciprocating saw, cut 1/2" (12.5mm) outside marked line. Be careful not to cut any framing members, concealed pipes or electrical wires (Diagram H).

Step 8: Using a flat bar, break asphalt sealing tabs of the shingles and carefully pull out staples or nails above the midpoint to upper edge of hole. Remove enough shingles to expose felt underlay at the middle of flashing hole.

Step 9: With a caulking gun, apply 1/2" (12.5mm) bead of sealant around underside of flashing along line of screw holes. Turn flashing upright and center over roof hole; fasten flashing to roof with 2" (51mm) flashing screws. Tighten screws until sealant is a minimum of 1/8" (3mm) and a maximum of 1/4" (6mm) thick between flashing and roofing material. Do not over tighten. Coat screw heads with sealant. Replace shingles. Fill all fastening holes and secure shingles tabs every 4" (102mm) with roofing sealant (Diagram J).

Curb Mount Flashing Installations (Diagram K).

Step 7: Center curb mount flashing onto constructed or manufactured curb. Check that flashing fits and that there are no obstructions in the way of tube's path.

Step 8: Run 1/4" (6mm) bead of roof sealant on top of curb where it will make contact with bottom of flashing.

Step 9: Fasten flashing to curb with eight 2" (51mm) flashing screws through sides of flashing. Do not over tighten screws.

Metal Roof

Refer to the Solatube Metal Roof Instructions.

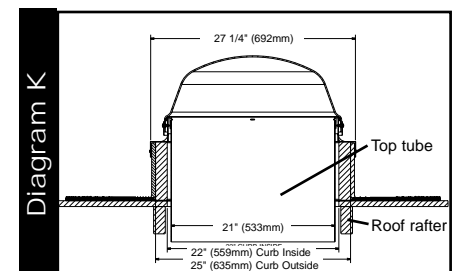
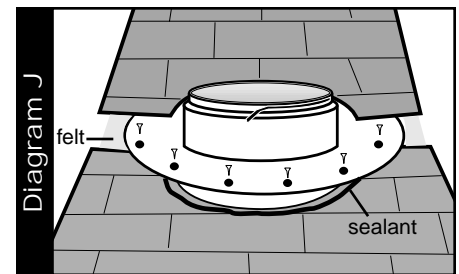
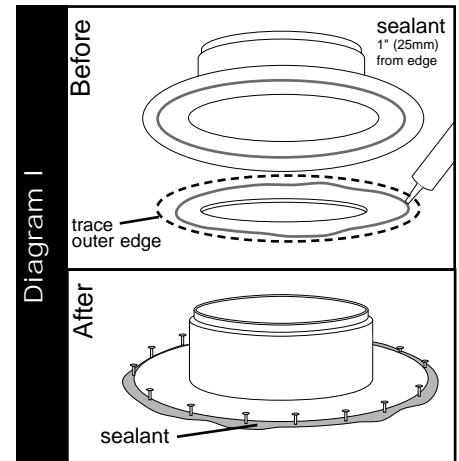
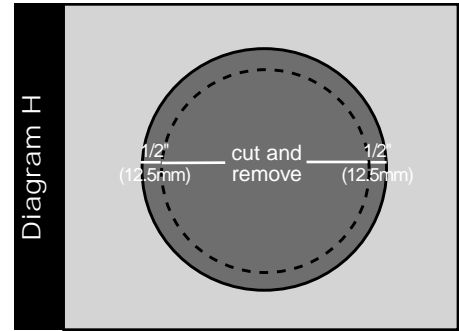
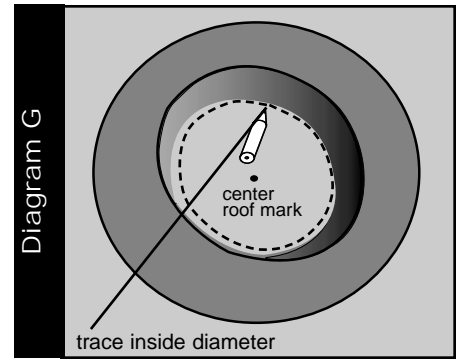

TOP TUBE INSTALLATION

Step 10: Insert top tube assembly into flashing and rotate angle adapter so that top tube aligns with bottom tube. Measure distance between tubes. "A" and "B" lengths should be equal (Diagram L). Bottom angle adapter can also be adjusted to achieve this measurement.

Record length for later use in determining extension tube requirements.

Step 11: Remove top tube assembly. If extension tubes are not required, tape angle adapter joint and tube seam. Screw three 3/8" (10mm) tube screws into angle adapter joint. If extension tubes are required, take top tube assembly with you to a level area where extension tubes can be made.

Note: If insulating flashing, pack fiberglass batt insulation around inside walls of flashing before inserting top tube assembly.

EXTENSION TUBE AND TOP TUBE ASSEMBLY

Step 12: Add 4" (102mm) to measurement in Step 10. This accounts for 2" (51mm) of extension tube inserting into both bottom and top tubes. Determine the number of extension tubes needed with each extension tube having 1 1/2" (38mm) tube overlap.

Step 13: Extension tubes can be formed into three sizes (Diagram M). For a larger diameter, weave opposite ends of tube through shallow notches and weave center tab. For the smaller diameter, weave opposite ends of tube through deep notches and weave center tab. For a tapered diameter, weave one end of tube through deep notch and the other end through shallow notch and weave center tab.

After forming the tube, firmly apply foil tape to vertical seam working out all wrinkles. Remove protective liner on inside of tube before installing.

Tapered tubes may be cut to length if necessary. If cut, always use factory cut end when joining extension tube to top tube.

Step 14: Remove protective liner from inside of top tube. Insert large diameter end of extension tube into top tube with a minimum 2" (51mm) overlap. Telescope extension tubes together with a minimum 1 1/2" (38mm) overlap at each joint to achieve tube length. Smaller diameter end of tube is always oriented down. Firmly apply foil tape around each tube joint and screw three 3/8" (10mm) tube screws through each overlapping tube joint (Diagram N).

Optional Transposition of Top Tube and Extension Tube (Diagram O)

Use an extension tube, as the top tube if additional vertical tube length from flashing is required to align top tube angle with bottom tube angle. Remove tape joint connecting dome ring to top tube. Push reflective tubing inward away from the dome ring tabs while pulling dome ring upward to release dome ring from top tube. Form a large diameter extension tube. Slide dome ring over pre-notched end of extension tube aligning tabs of dome ring into notches. Expand extension tube end to fit tight to dome ring. Foil tape vertical seam and dome ring to extension tube. Screw three 3/8" (10mm) tube screws from inside top tube into dome ring. Install top tube angle onto end of top extension tube per instruction.

Note: If top or bottom angle adapter happens to separate, simply slide top half of angle over bottom half of angle, lining up riveted seams. With rivets lined up, connect tube angle together starting at wider section of top half. Raise opposite side of bottom half angle tube as you guide angle grooves back together (Diagram P).

INSTALLATION OF TUBE ASSEMBLY

Step 15: Take top tube/extension tube assembly to roof flashing location. Insert through flashing and lower over bottom tube. Adjust top tube angle so dome ring rests evenly onto flashing. Make corresponding marks to dome ring and flashing for re-alignment of assembly when reinserted (Diagram Q). Remove top tube assembly. Foil tape tube angle and screw three 3/8" (10mm) tube screws into tube angle joint (Diagram N). Re-insert assembly into flashing and align marks.

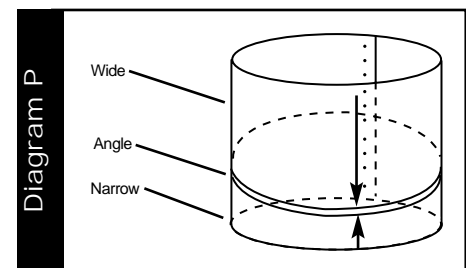
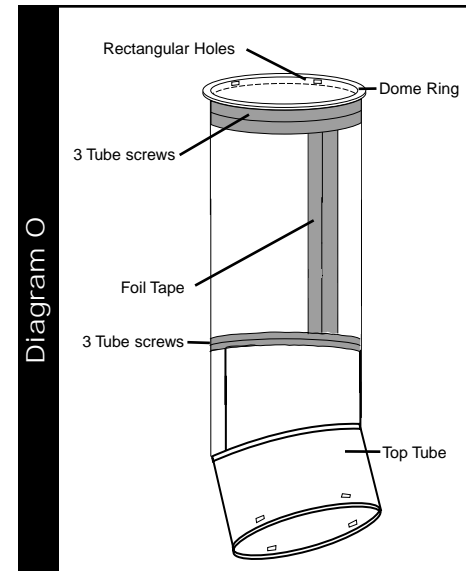
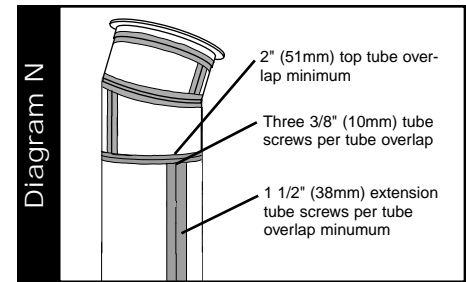
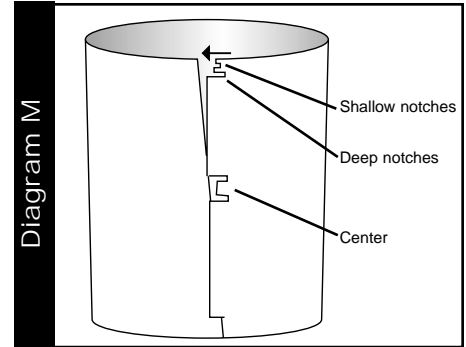
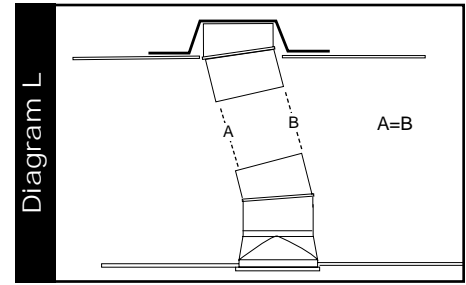

LITD AND DOME INSTALLATION

Step 16: Peel protective liner from LITD. Using a magnetic compass, position LITD with reflective side facing inside and due south. Insert mounting tabs on LITD between top tube and dome ring (Diagram R).

Step 17: Place dome over LITD and flashing until dome rests evenly on dome ring.

Step 18: Insert nylon dome spacers into dome holes. Fasten dome to flashing using 3/4" (19mm) dome screws. Tighten screws tight against spacer (Diagram S).

COMPLETION OF TRANSION BOX INSTALLATION

Step 19: Foil tape bottom tube angle adapter and extension tube joints.

Step 20: Screw three 3/8" (10mm) tubescrews into overlapping tube joint (Diagram T).

Step 21: Foil tape transition box to bottom tube. Screw four 3/8" (10mm) tube screws through bottom tube into transition box (Diagram T).

INSTALLATION OF DIFFUSER PANEL

Step 22: Insert diffuser seal into the groove on topside of diffuser frame. Cut seal long to keep constant pressure against itself (Diagram U).

Step 23: Position diffuser panel into transition box and lock in by pushing clips into notches provided.

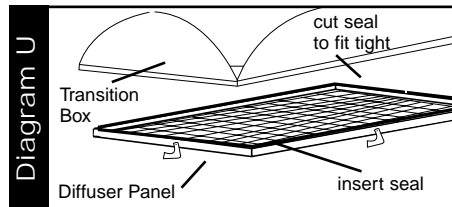
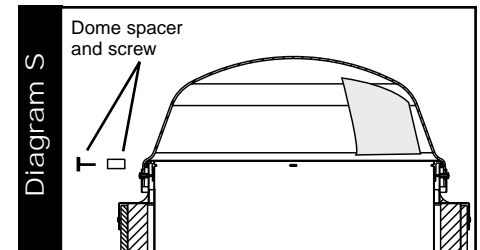
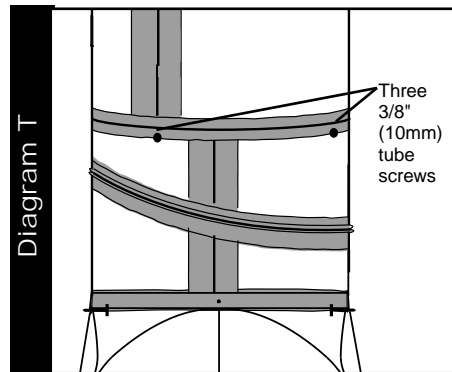
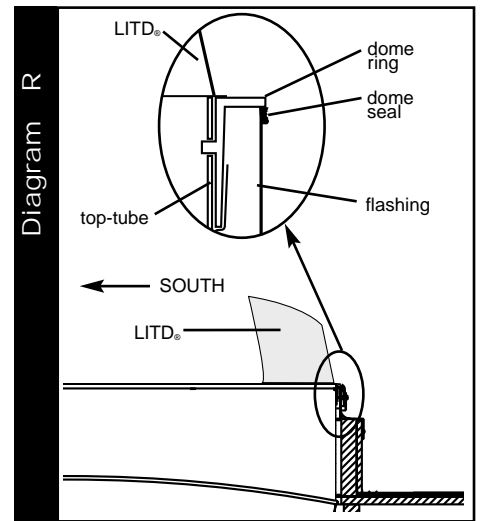
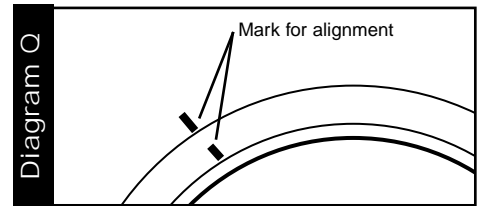

Dome Edge Protection Band

Dome edge protection band required for fire-rated roofs when using the 4" flashing on the 21" Solatube. Dome edge protection band sold separately.

Addendum to parts list:

1. 21" (533mm) Dome Edge Protection Band (1)

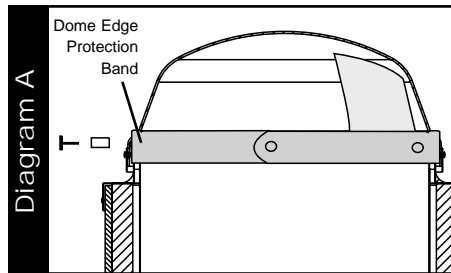

Step 1: Insert nylon dome spacers halfway into dome holes. Starting with the middle hole in band, slide band over spacer and fasten using 3/4" (19mm) dome screw. Continue installing screws in both directions. The last screw will go through the two holes in the band where it overlaps (Diagram A).

Suspension Wires

Suspension wires ordered separately.

Addendum to parts list:

1. Suspension eye screw - 3" 975mm (4)
2. Suspension wire -16 guage, galvanized (roll) (50')
3. Suspension eyebolt, nut and washers (4)

After step 21 above, before installation of diffuser panel, complete the following steps:

Step 1: Insert the four eyebolts with one washer from outside of the transition placing another washer with nut on inside (Diagram A).

Step 2: Attach the four suspension eye screws into the roof framing at four suitable points. String anchor tie wire with minimum three wraps to each hanger fastener and transition box eyebolt. Ensure correct transition box location is maintained (Diagram B).

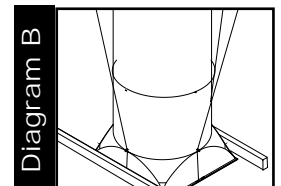
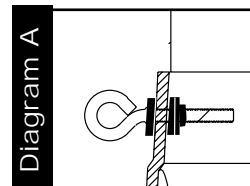

Solatube International, Inc.
2210 Oak Ridge Way, Vista, CA 92083-8341
Phone (800) 966-7652 Fax (760) 599-5181
www.solatube.com