

Solatube Installation Instructions

Metal Roof 10" (250mm), 14" (350mm), 16" (400mm)

Parts List

Item No.	Description	Qty. Required*		
		10" (250mm) 75" (1900mm)	14" (350mm) 80" (2000mm)	16" (400mm) 87" (2200mm)
1	Sealant Tape - Butyl			
2	Flashing Screw	16	18	20
3	Speed Nut	16	18	20
4	Corner Washer	2	2	2
5	Sealant Cartridge Polyurethane (not included)	1	2	2

*Kit includes parts for 16" (400mm)
Polyurethane sealant must be ordered separately.

1. Sealant Tape - Butyl
2 1/2" (64mm) x 3/16" (5mm) thick

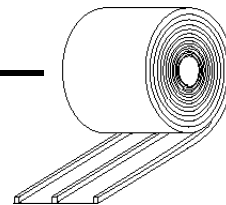

2. Flashing Screw - 2" (50mm) stainless steel



3. Speed Nut



4. Corner Washer - 3" (76mm) dia.



5. Sealant Cartridge - Polyurethane
(ordered separately)



2210 Oak Ridge Way, Vista, CA 92083
800 966 7652 • 760 599-5181 (fax) • www.solatube.com

COMPLETE STANDARD INSTRUCTIONS THROUGH "ROOF LOCATION"

SPECIAL NOTE: Please read these instructions beginning to end before cutting any holes or parts.

NOTE: For Ribs less than 2-1/2" (64mm) tall, use 4" (102mm) tall flashing. For Ribs greater than 2-1/2" (64mm) and less than 4-1/2" (114mm) tall, use 6" (152mm) tall flashing. If ribs which are to be cut form structural supporting elements of roof, care must be taken to reinforce roof area. Consult experts if uncertain in roof structural requirements. For Flat Metal roofs ignore reference to " ribs". For Corrugated Metal roofs as well as Pressed Metal Tile roofs (horizontal panels), contact your Solatube Distributor for alternative flashings. Consult building experts if weather conditions, or lack of adequate attic ventilation or vapor barrier may promote condensation on internal metal surfaces.

NOTE: Depending on rib pattern as well as size and location of flashing; the turret may intersect: none, one, or multiple ribs. When necessary to trim flashing flange due to conflict with adjacent rib, maintain minimum 2-1/2" (64mm) wide flange and rib/turret spacing to provide adequate sealant bed and adequate width for water runoff. If water flow is significantly blocked, water level may rise above rib overlap joint and cause leaks.

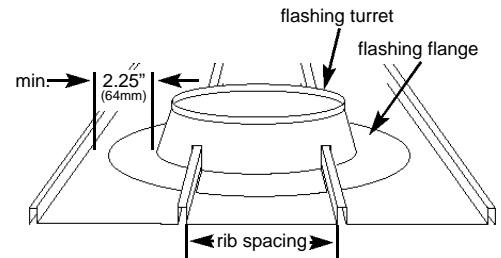

Step 1. For 4" (102mm) high flashings, draw a circle 1" (25mm) smaller than the inside of the turret base onto the roof panel. For 6" (152mm) high flashings, draw a circle 1-3/4" (44mm) inside of the turret base. Draw a second line outlining the outer flange perimeter. **NOTE:** Either octagonal or round cut flashing bases may be used. **Diagram A**

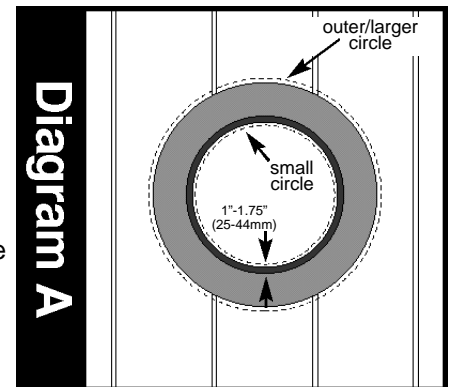

Step 2. On the lower half of the flashing, trace the intersecting outline of the roof panel rib(s) onto the base flange and turret section as shown. **Diagram B**

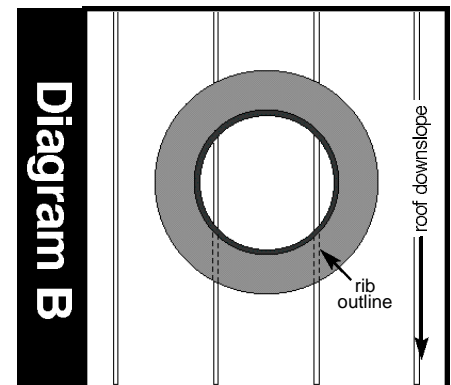

Step 3. Remove flashing. For 4" (102mm) high flashings, draw a horizontal line 2" (51mm) above top edge of smaller circle. For 6" (152mm) high flashings, draw a horizontal line 2-3/4" (70mm) above top edge of smaller circle. From the two points where this line intersects the outer circle, connect two straight lines to the small circle as shown. With tin snips, cut roof panel along resulting tulip shaped line (marked cutout area). **Diagram C**

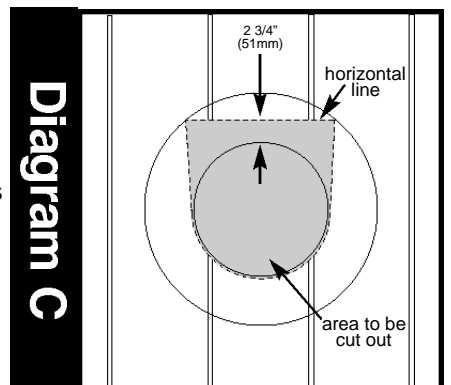

Step 4. If rib segments are more than 1/4" (6mm) wide, cut and form end caps out of scrap cutout material and cap the up-slope ribs. **Diagram D & E**

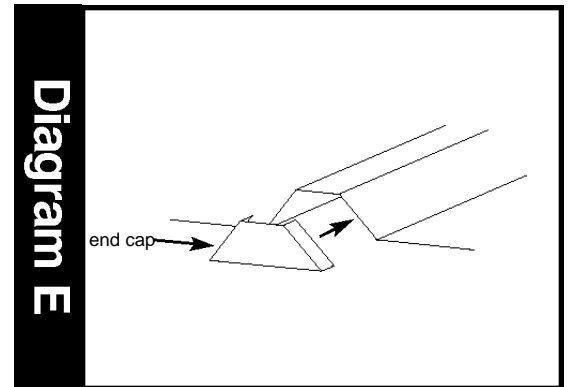
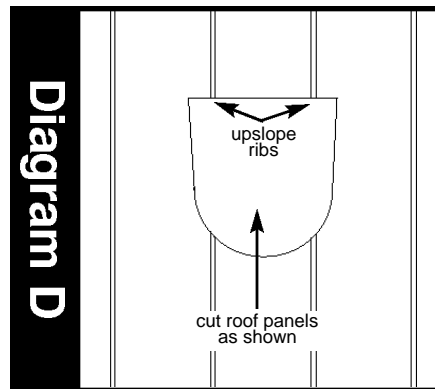

Step 5. Slip upper edge of flashing base under horizontal cut in roof panel then lower flashing onto roof. **Diagram F** Cut lower portion of flashing as outlined in step 2 to allow roof ribs to protrude through flashing as shown in **Diagram G & H**. Ensure the flange fits snugly into upper corners of roof hole and lower portion of flashing fits tightly over rib(s).

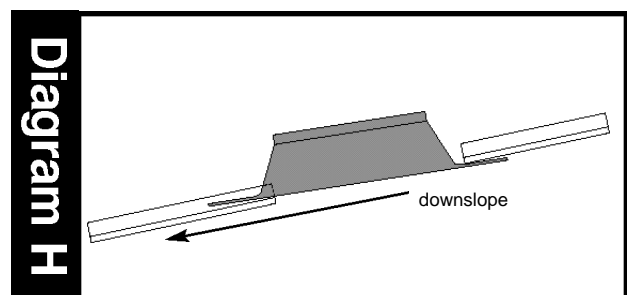
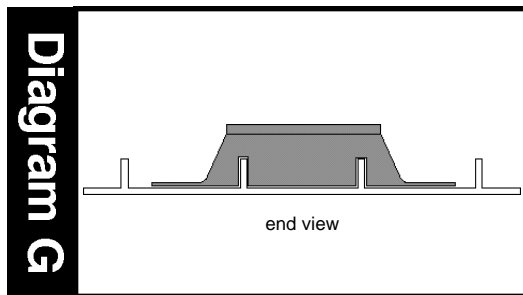
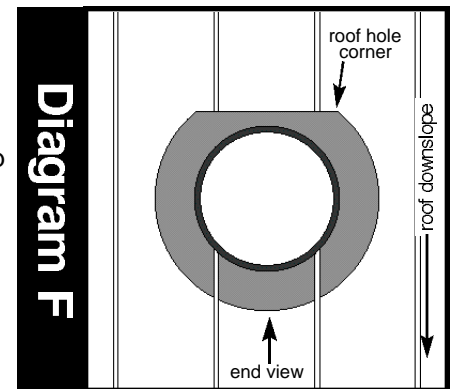

Step 6. Trace a line along the horizontal roof cut onto flashing base. Remove flashing and apply butyl sealant tape on top of the upper portion of the flashing 1/4" (6mm) above the horizontal roof cut line. Apply butyl sealant tape on the bottom of the lower portion of the flashing base 1/4" (6mm) in from the outer edge starting and ending below the horizontal roof cut line (include area around the rib cut-out(s)). Set flashing aside. Fill exposed roof rib ends with extra butyl sealant tape to seal ends. Note: To apply butyl sealant tape, unroll directly onto flashing surface as you remove backing paper. Butyl tape will not bend around corners without removing backing.

Diagram I

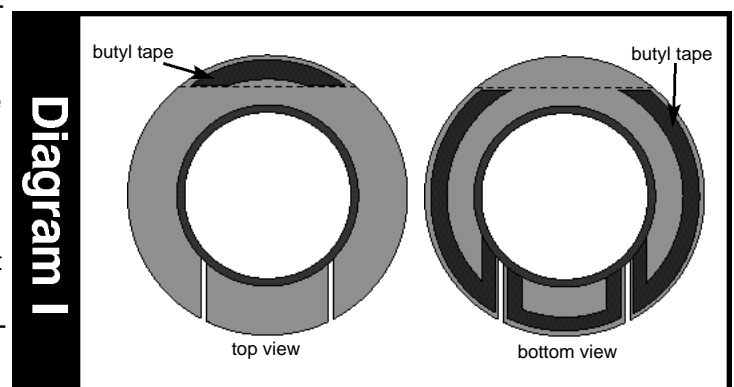

Step 7. Using wire brush, appropriate solvent, and rag, clean and dry roof surfaces that will come in contact with flashing. Install flashing snugly into the roof panel. Ensure that flange fits snugly into upper corners of roof hole and lower portion of flashing fits over rib(s).

Pre-bore 3/16" (5mm) holes at the intersection of flange and horizontal roof cut out, at 5" (127mm) increments, and adjacent to both sides of ribs as shown. Then drive flashing screws through flashing and roof panel as shown. Place speed nuts (flat side up) on downside of roof panel, over protruding screw shanks, and tighten fasteners to sandwich butyl sealant tape. Note: Use vicegrips to hold speed nuts. **Diagram J**

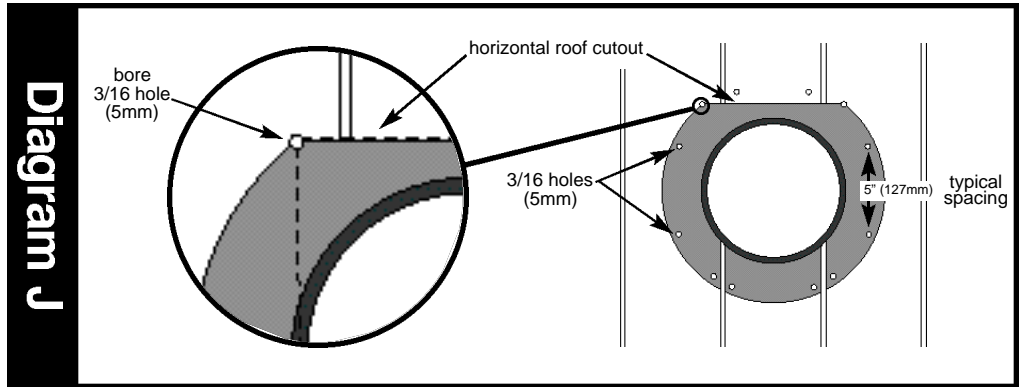

Step 8. Apply butyl sealant tape to one side of two corner washers and insert fasteners as shown. Place speed nuts (flat side up) over protruding screw shanks and tighten fasteners to sandwich butyl sealant tape. **Diagram K**

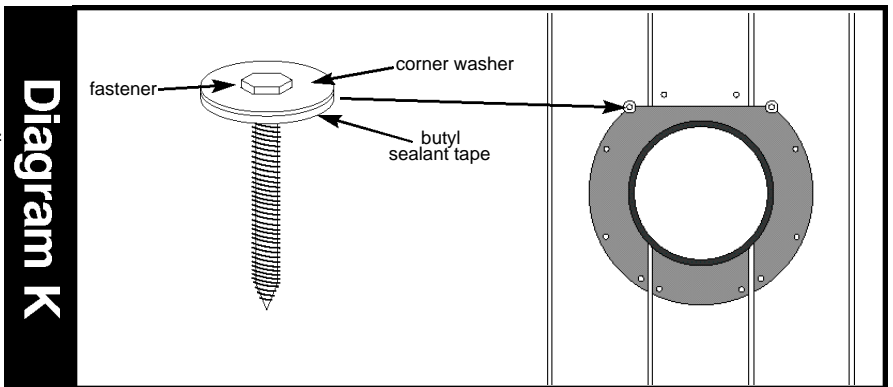

Step 9. Spread polyurethane roof sealant over joint between rib and turret located inside turret. **Diagram L**

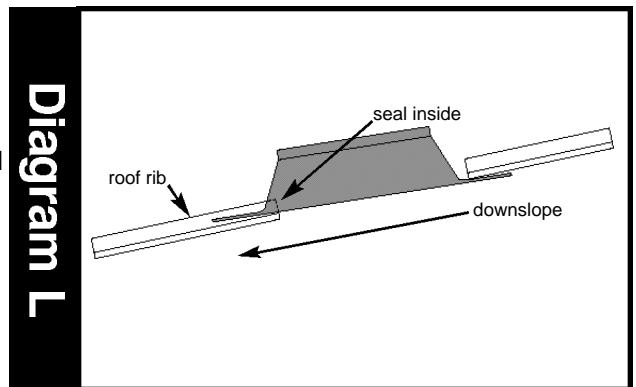

Step 10. Force a 1/2" (13mm) bead of polyurethane roof sealant into all exposed overlap joints and fastening penetrations. Force into crevices, then detail and feather edges with putty knife. Be sure to cover all exposed butyl tape with polyurethane sealant as butyl tape is not designed to be exposed to outside elements. This will also prevent dirt and dust buildup on the butyl tape. **Diagram M**

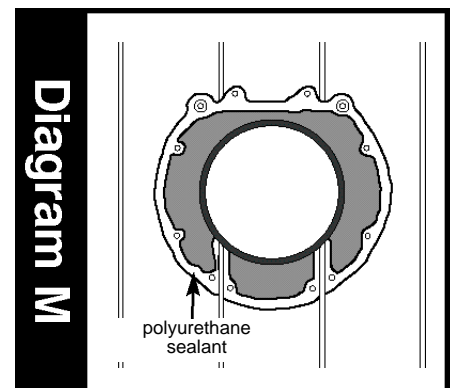

RETURN TO STANDARD INSTRUCTIONS TO COMPLETE INSTALLATION